

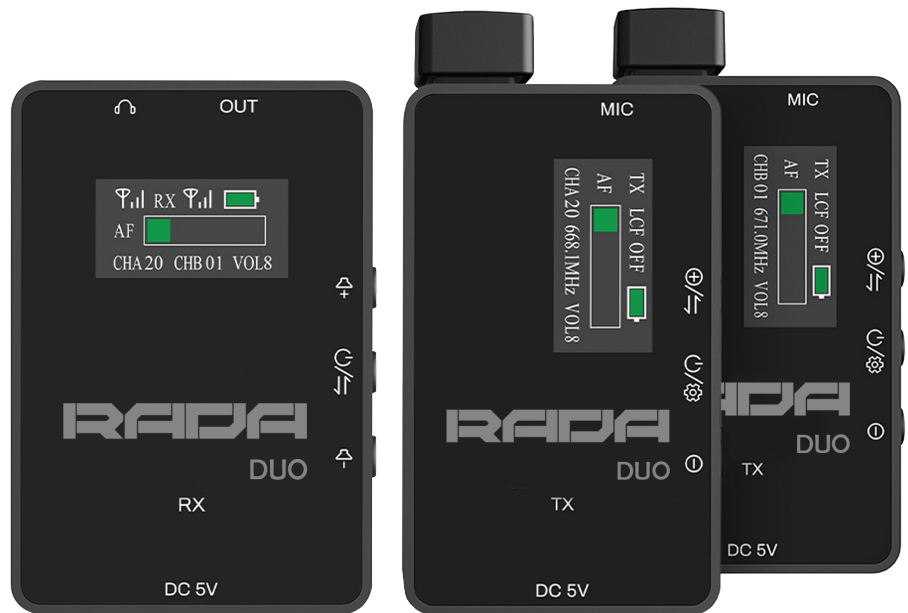

RADA



**CLIP, WALK AND
TALK WITH RADA DUO**

RADA DUO

QUICK INSTALLATION GUIDE

RADA Duo Quick Installation Guide

RADA Duo is a wireless microphone system with a miniature and lightweight design, high-quality audio, extended battery life, and precise noise cancellation, including the LCF mode for particularly loud environments. The Duo prioritizes flexibility and features clips on both the receiver and transmitters, allowing them to be easily attached to jackets, shirts, or belts.

The system utilises UHF wireless transmission to guarantee exceptional signal stability and professional-grade audio quality. RADA Duo is designed as a dual-channel system capable of processing audio from two microphone transmitters simultaneously. It also supports volume monitoring and adjustment through convenient hotkeys.

Duo is primarily designed for use with AREC Media Stations, enabling users to capture the voices of presenters and guests. Nevertheless, it has a variety of other applications. You can also utilise it with cameras, tablets, mobile devices (such as phones), PCs, AV audio mixers, and other recording and streaming equipment.

WARNINGS



1. A certain level of ambient noise is inevitable in especially noisy environments.
2. Store the product in a dry and clean area when not in use. Avoid storing it in hot and humid locations, as this can impact the product's sensitivity and tone.
3. Refrain from pulling or bumping the cables, as this can lead to a decrease in microphone sensitivity or damage to the cables.
4. Ensure the devices remain dry and avoid handling them with wet hands. Please note that RADA Duo is not waterproof; therefore, refrain from exposing it to rain or water.

PRECAUTIONS

1. Ensure that all cables are correctly inserted before using the devices.
2. RADA Duo is outfitted with rechargeable lithium batteries, which, like all batteries, have a finite lifespan. As time passes, the maximum operating hours will diminish. To prolong the battery life, consider the following measures:
 - Disconnect the power cord after the device completes charging.
 - Completely discharge and recharge the batteries at least once every three months.

Package Contents

- x1 Receiver
- x2 Transmitter microphones
- x1 Cold shoe mount for installations on cameras
- x1 Mobile phone clip
- x2 Windshields for transmitters
- x2 Lavalier microphones with clips for transmitters
- x1 1-to-3 USB Type-A to USB Type-C charging cable
- x1 3.5mm TRRS to 3.5mm TRRS cable
- x1 3.5mm TRRS to 3.5mm TRS cable
- x1 3.5mm TRRS to USB Type-C cable
- x1 USB Type-C to USB Type-A adapter
- x1 3.5mm Female to 6.5mm Male adapter
- x1 Carry bag

RADA Duo Transmitter Microphone

1. Transmission : UHF
2. Voltage : 3.7V lithium battery
3. Current : 100mA@3.8VDC
4. Microphone type : omni-directional
5. Frequency : 650~690MHz
6. Frequency stability : <15ppm
7. Transmission power level : 13dBm/3.8VDC
8. Frequency response : 50Hz~15K Hz
9. Operating distance : 50 meters, depending on the environment
10. Battery capacity : 3.7V/480mAh
11. Time to full charge : 1.5 hours
12. Endurance rating : approximately 4 hours
13. Net weight : approximately 70g
14. Dimensions : 71mm X 37mm X 14mm

RADA Duo Receiver

1. Frequency : 650~690MHz
2. Frequency stability : $< \pm 15\text{ppm}$
3. Distortion : $< 0.5\%$
4. Audio Delay : $< 2.5\text{ms}$
5. Frequency response : 50Hz~15K Hz
6. Sensitivity : $< -105\text{dBm}$
7. Dynamic range : $>85\text{dB}$
8. Operating distance : 50 meters, depending on the environment
9. Battery capacity : 3.7V/800mAh
10. Time to full charge : 2 hours
11. Endurance rating : approximately 6 hours
12. Net weight : approximately 86g
13. Dimensions: 62mm X 42mm X 16mm

Icon Description

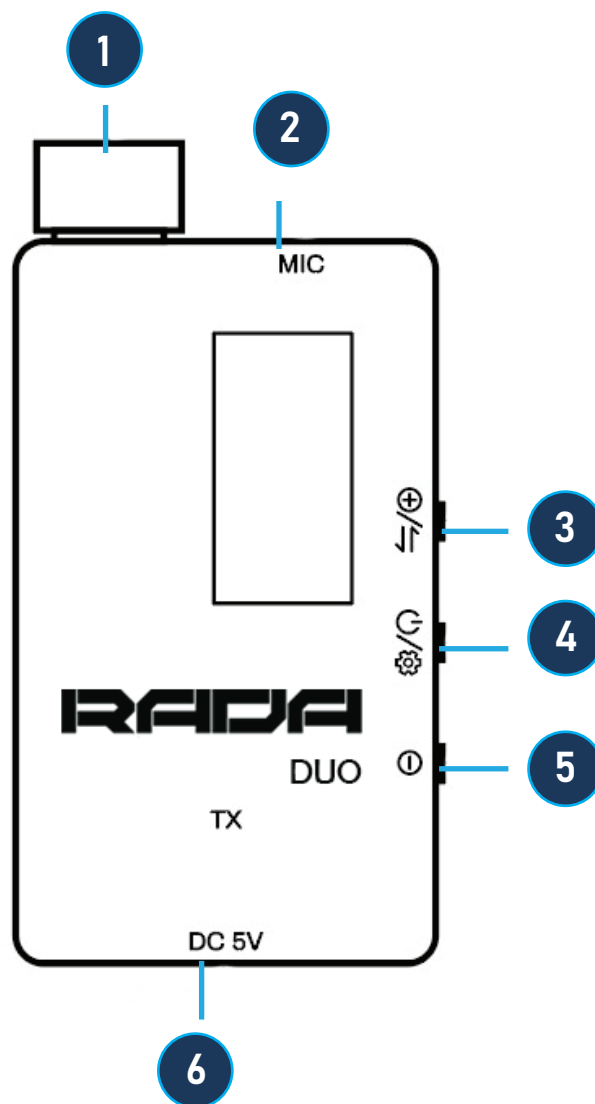

1. Microphone
2. Microphone input : Designed for a 3.5mm TRS connector
3. "+" Function key and coding key : Tap to increase when configuring settings or press 3 times in a row to enter coding mode
4. Power button and function key : Press for 2 seconds to turn on or off or tap to scroll through customizable settings
5. "-" Function key : Tap to decrease when configuring
6. Charging port : Designed for USB Type-C, input 5V1A

Icon Description (Launcher TX)

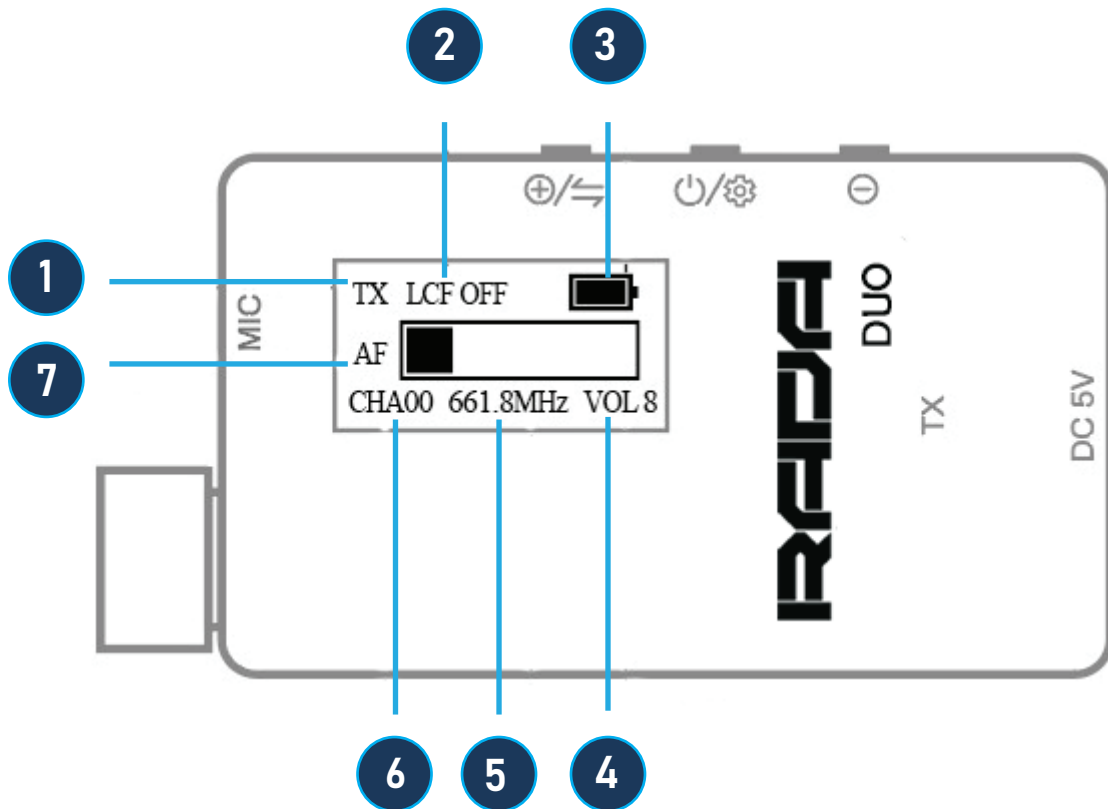

1. TX transmitter icon
2. LCF (low cut filter) : Enable it when in a particularly noisy environment
3. Battery charge indicator : Indicator flashes when charging and stops when fully charged
4. Volume level : You can set it from 0 to 8
5. Frequency : 650 to 690 MHz are supported
6. Channel : 0 to 20 are available
7. Audio Frequency : Dynamically shows audio level

Icon Description

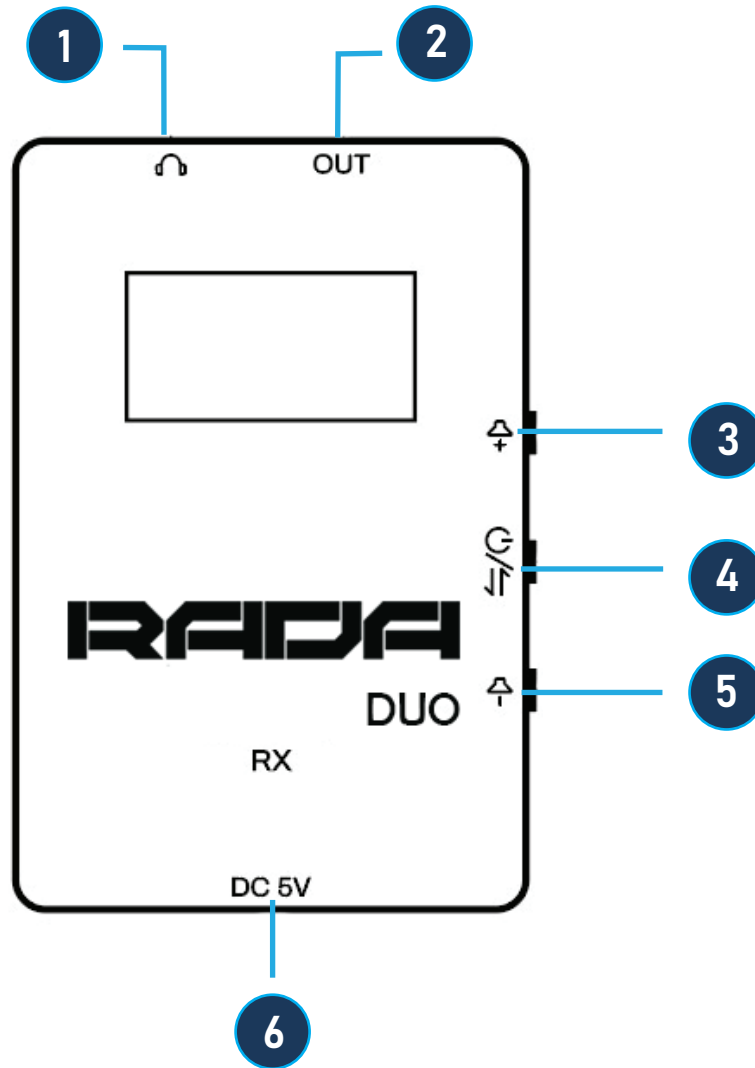

1. Monitoring port : Designed for 3.5mm TRS or TRRS headphones
2. Audio output port : Connect to other devices for audio recording via 3.5mm TRRS connector
3. Volume “+” control key : When powered on, press to increase volume
4. Power button / coding key : Press for 2 seconds to turn on or off or press 3 times when powered on to enter coding mode
5. Volume “-” control key : When powered on, press to decrease volume
6. Charging port : Designed for USB Type-C, input 5V1A

Icon Description (Receiver RX)

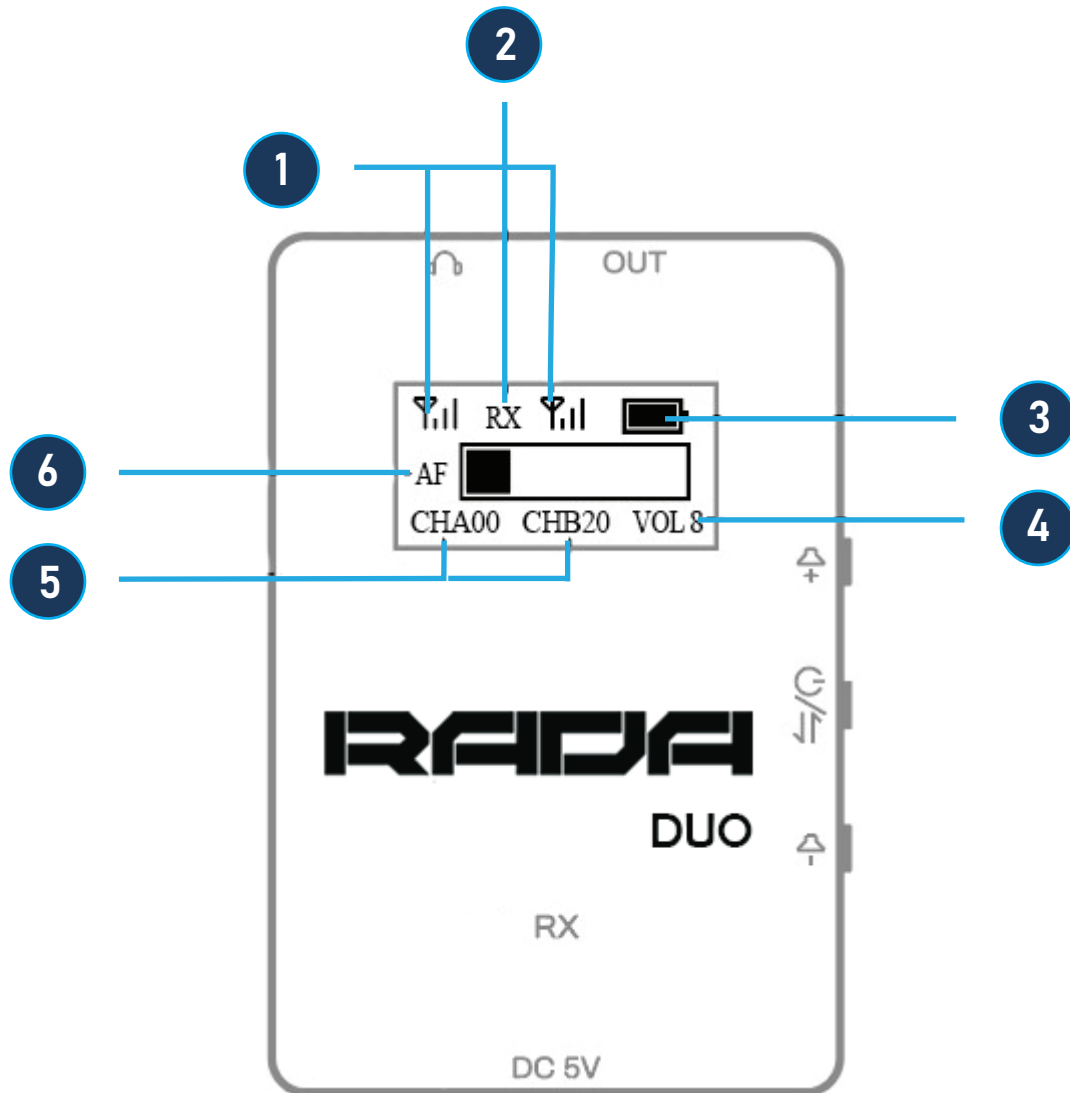

1. Signal strength
2. RX receiver icon
3. Battery charge indicator : Indicator flashes when charging and stops when fully charged
4. Volume level : You can set it from 0 to 8
5. CHA (Channel A) and CHB (Channel B) indicators : 0 to 20 are available
6. Audio Frequency : Dynamically shows audio level

Cables Overview

1. 3.5mm TRRS to 3.5mm TRS cable. Primarily used to connect to DSLR cameras and camcorders.



2. 3.5mm TRRS to 3.5mm TRRS cable. Primarily used to connect to AREC Media Stations, PTZ cameras, and mobile phones.



3. 3.5mm TRRS to USB Type-C cable. Primarily used to connect to computers and mobile phones.



4. USB Type-C to USB Type-A adapter. Primarily used to connect to AREC Media Stations and computers with USB Type-A ports.



5. 1-to-3 USB Type-A to USB Type-C charging cable. Used to charge RADA Duo Receiver and Transmitters.

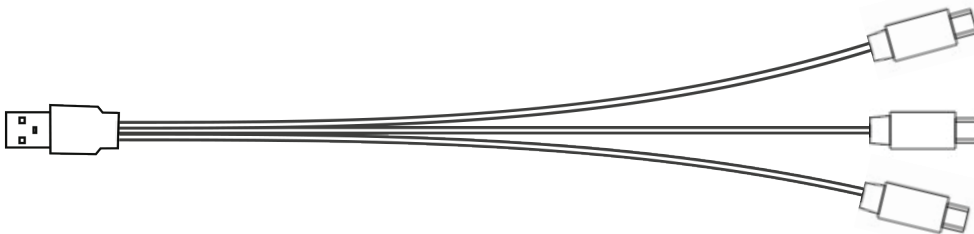

6. 3.5mm to 6.5mm adapter. Primarily used to connect to professional audio equipment, amplifiers, and musical instruments.



Quick Installation Guide

Transmitter

The transmitter can be used with the inbuilt microphone or with an external 3.5mm TRS microphone. If you would like to use an external microphone, input it into the “MIC” port as indicated on the device.

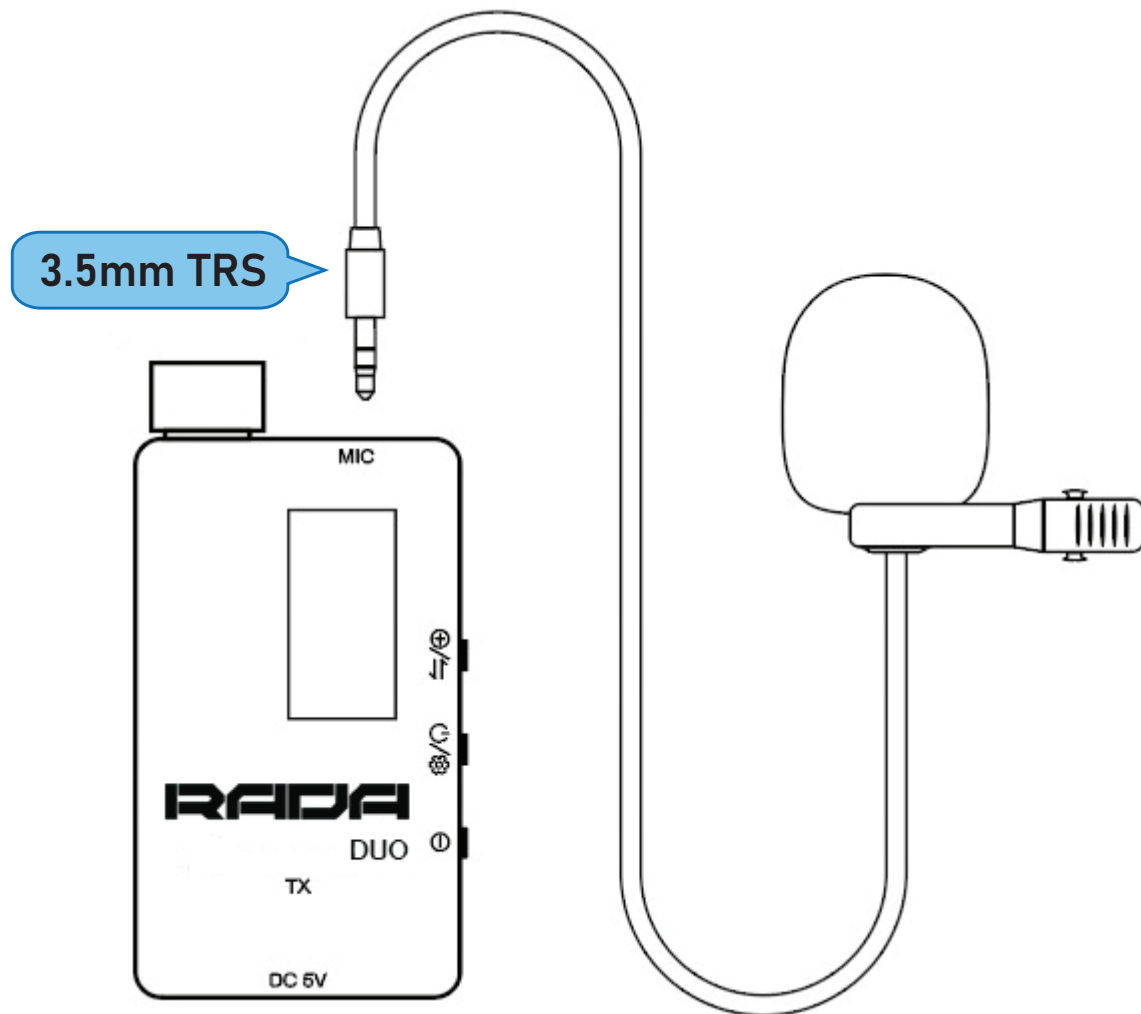

Receiver

The receiver can be connected to a camera using the provided cold shoe like this :

1. Secure the receiver on the cold shoe mount
2. Secure the cold shoe mount on the camera and tighten it
3. Connect the receiver to your camera using the provided 3.5mm TRRS to 3.5mm TRS cable

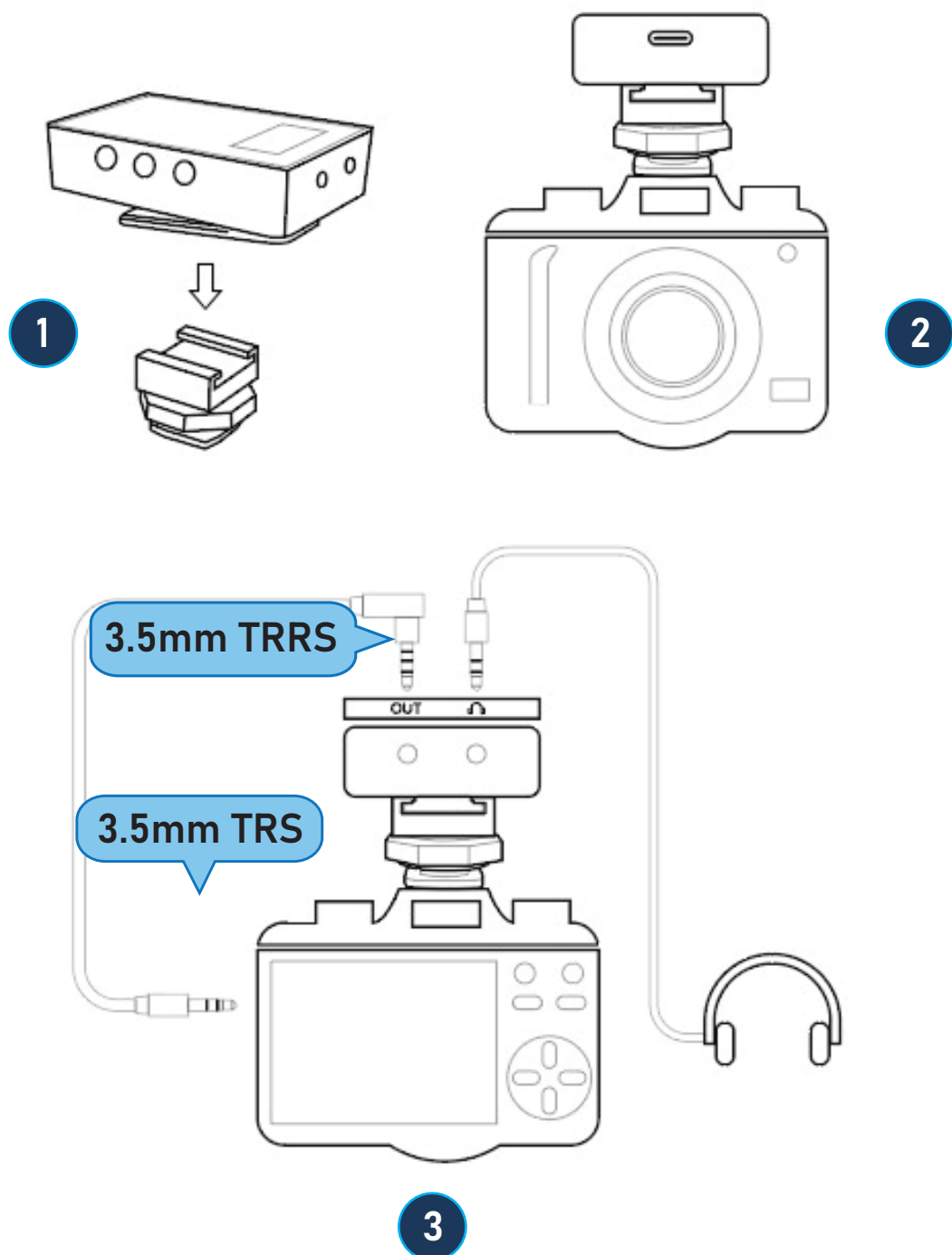

When using with a Media Station with 3.5mm inputs

When connecting the receiver to a Media Station with 3.5mm inputs, use the provided 3.5mm TRRS to 3.5mm TRRS cable. Connect it to the headset output on the receiver and to the line input on the Media Station.

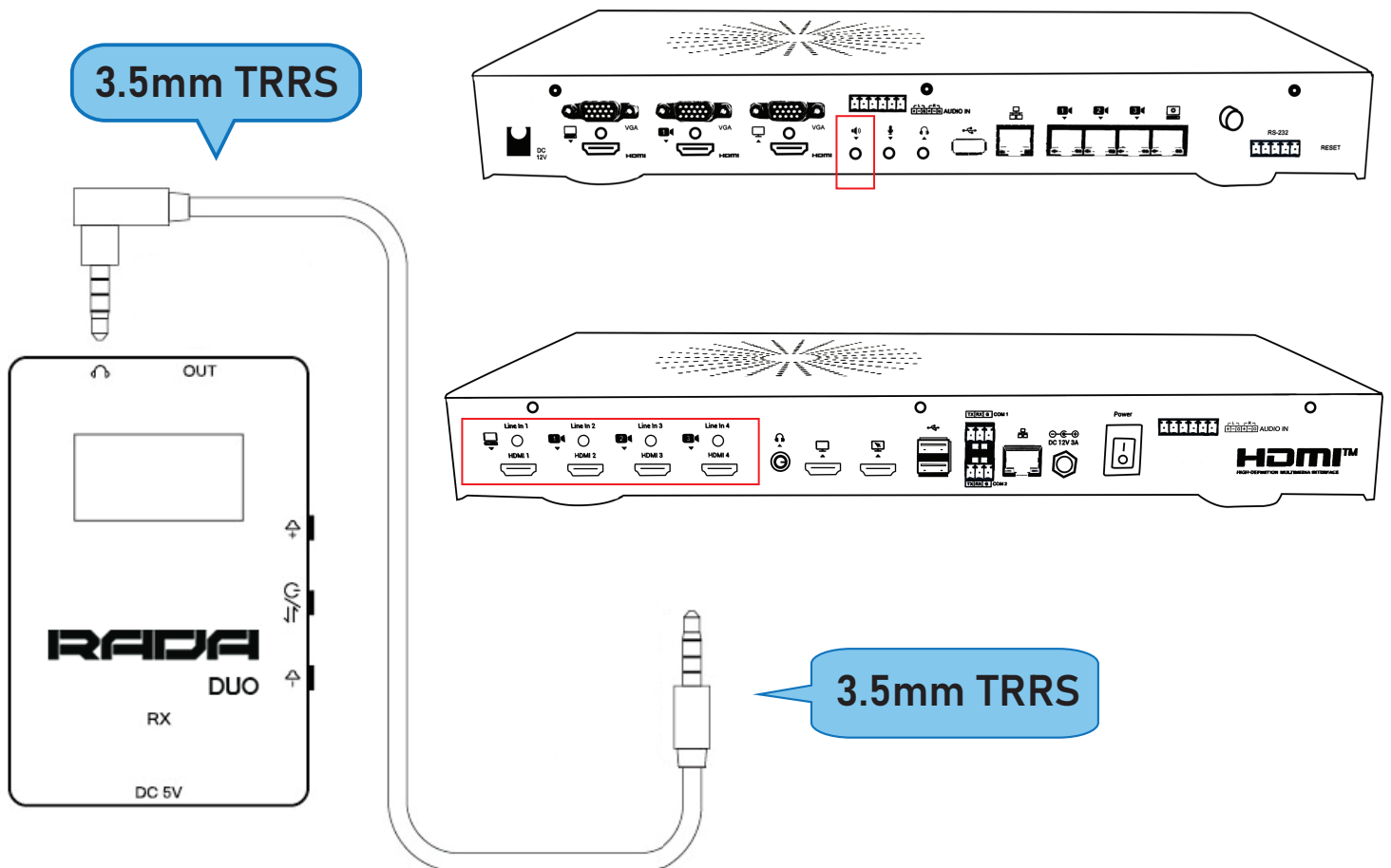

When using with stations without 3.5mm audio inputs

When connecting the receiver to a Media Station without 3.5mm inputs, use the provided 3.5mm TRRS to USB Type-C cable and the Type-C to Type-A adapter. Connect the 3.5mm cable to the line output (labelled 'Out') on the receiver and Type-C to the adapter. Connect the adapter to your Media Station (you can use any USB port for this).

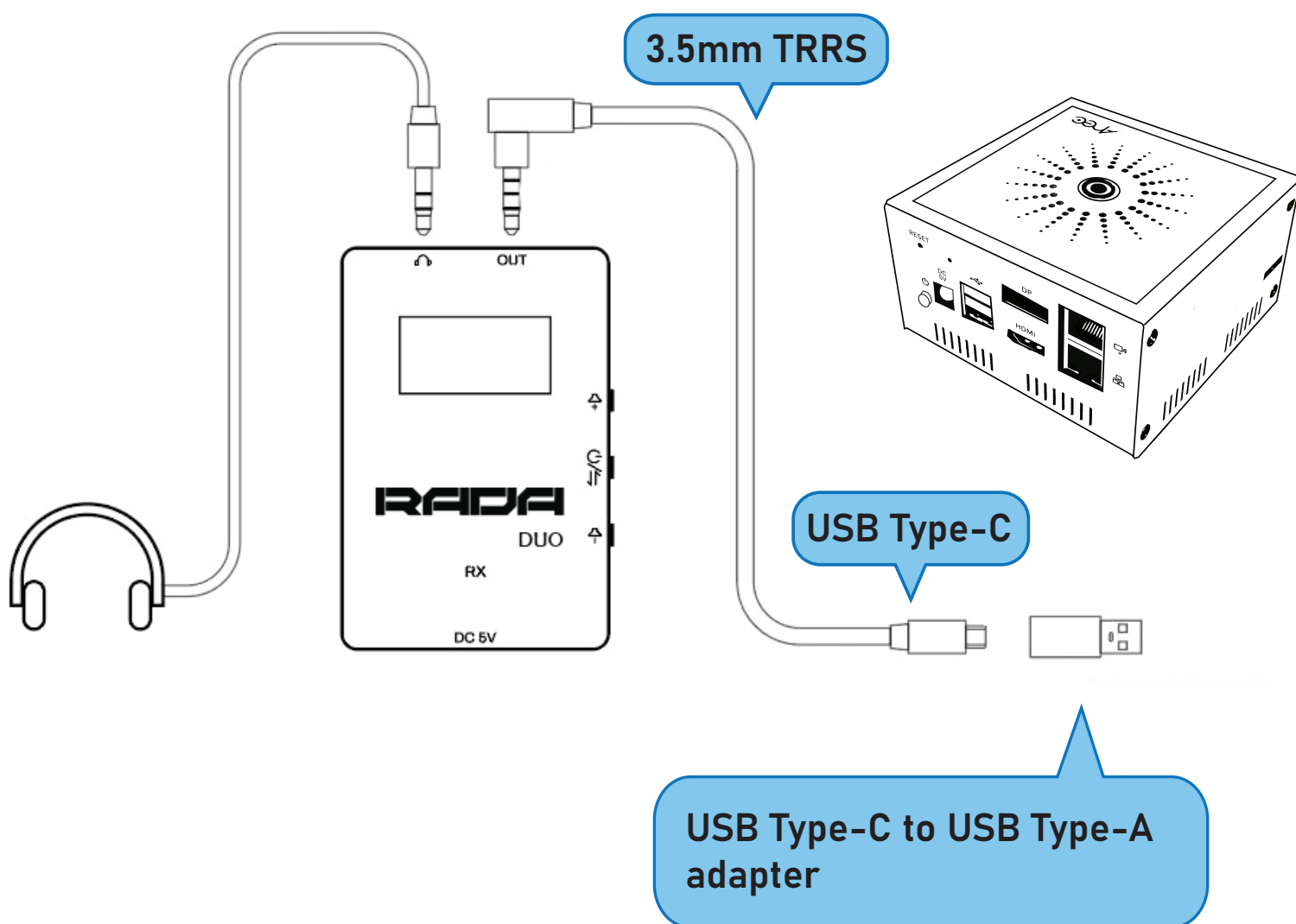

When using with a phone

When connecting the receiver to a cellphone, use either the provided 3.5mm TRRS to 3.5mm TRRS or 3.5mm TRRS to USB Type-C, depending on your device.

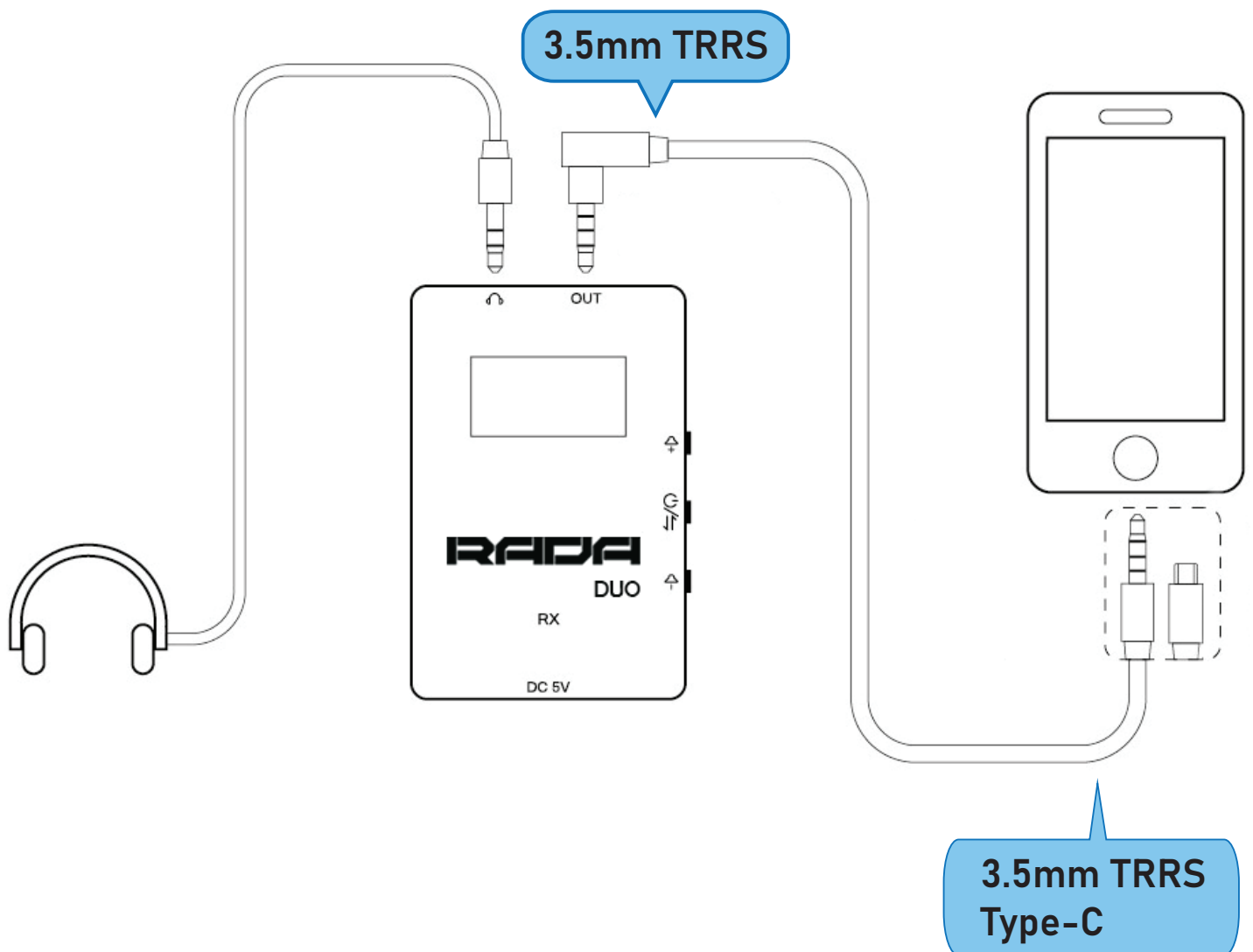

When using with a computer

When connecting the receiver to a computer or other devices, you can use the provided 3.5mm TRRS to USB Type-C, with our without USB Type-C to USB Type-A adapter, or the provided 3.5mm TRRS to 3.5mm TRRS cable, depending on your computer's audio jacks.

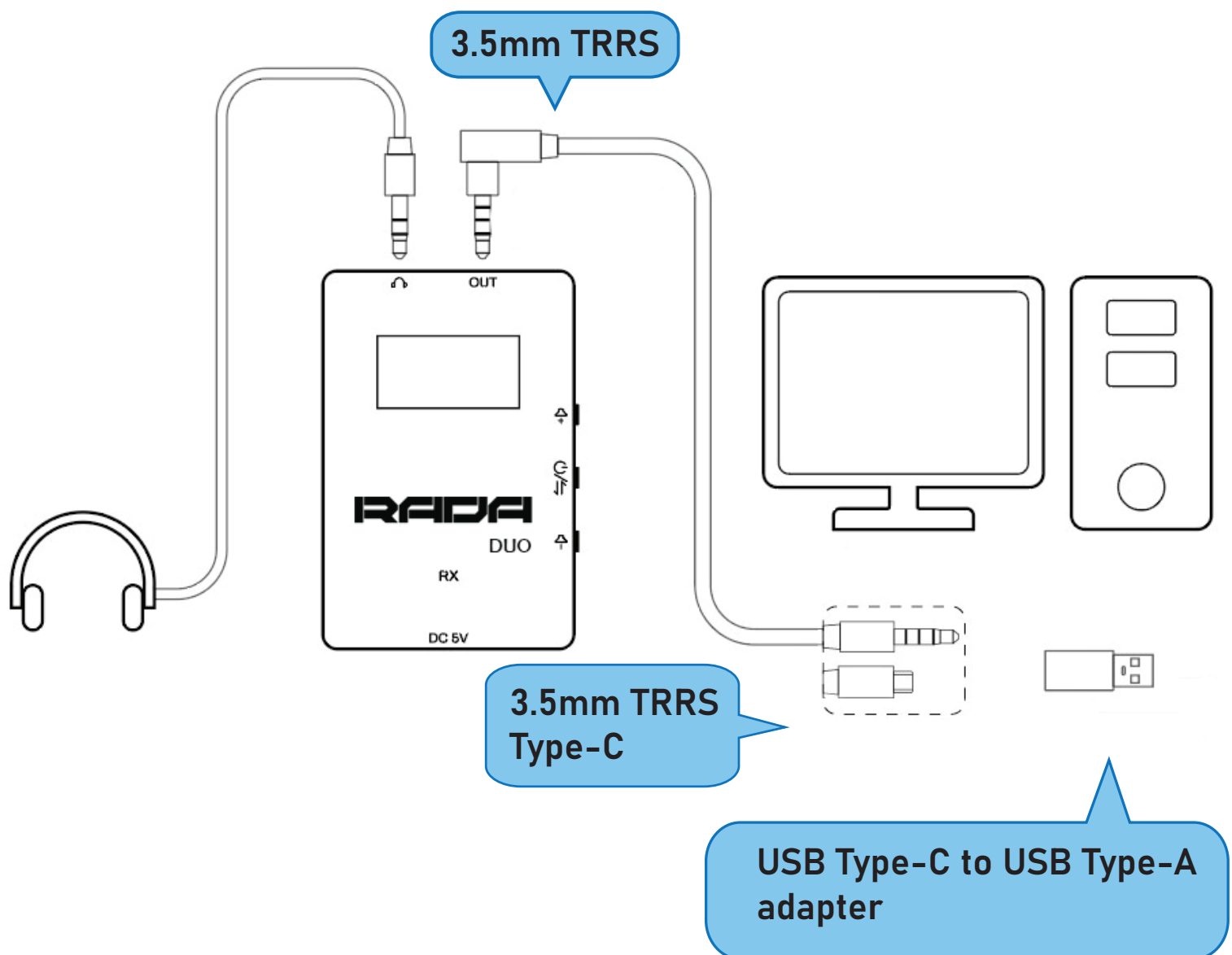

Configuring the devices

Transmitter Configuration

Press the power button for 2 seconds to turn the device on or off. Once powered on, use the power button to cycle through options for setting up channels, volume, or LCF. Adjust these settings using the “+” or “-” buttons. Changes are automatically saved after 2 seconds. You can also save manually by pressing the power button.

Receiver Configuration

To adjust the volume on the receiver, press the “+” button to increase and the “-” button to decrease.

Devices are shipped already paired. If you need to re-pair the devices or correct channel misalignment, follow this procedure:

1. Power on the devices.
2. On the receiver, press the power button three times to enter pairing (coding) mode.
3. On the transmitters, press the "+" button three times to do the same."

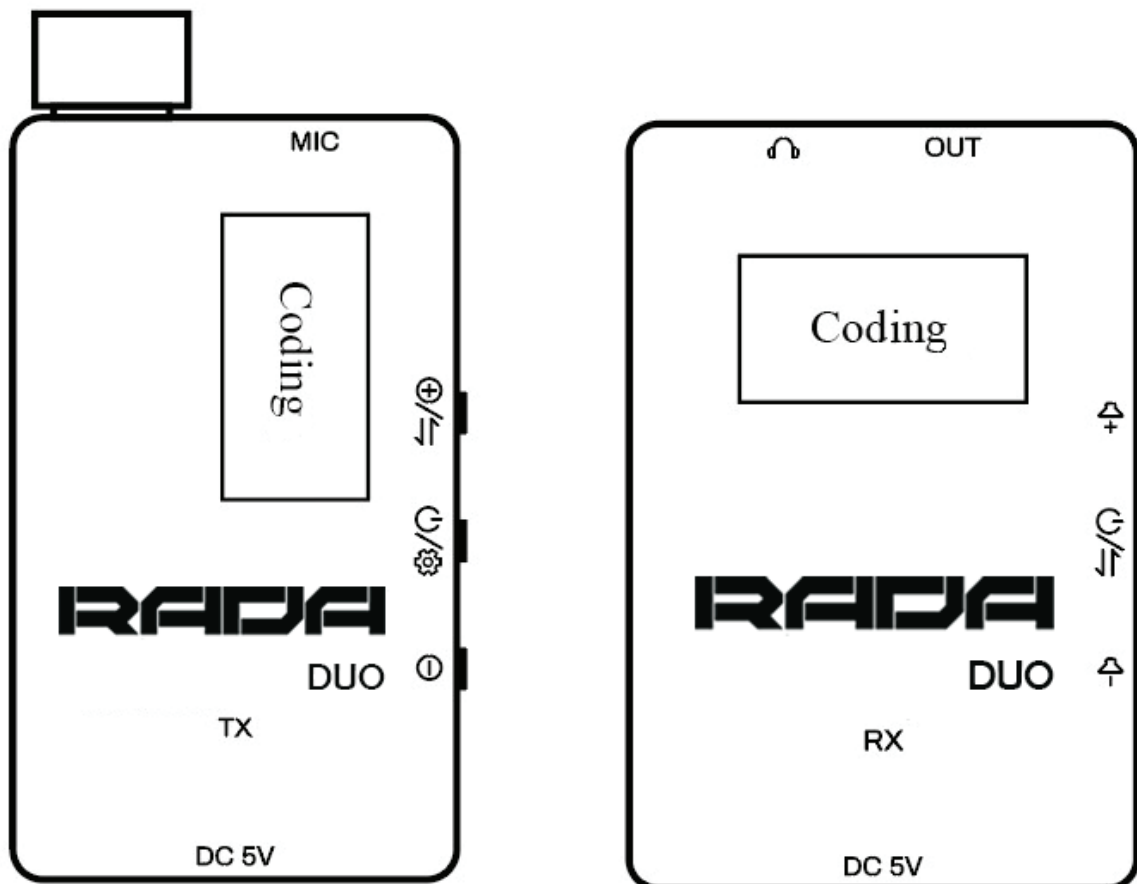

Troubleshooting

1. Objects and walls can block the devices and reduce their effective range. In crowded environments, human bodies can attenuate radio waves, so it's essential to keep the devices unobstructed. If you encounter interference or a weak signal, consider clearing obstacles
2. When using the devices outdoors or speaking directly into the microphone, using the windshield is recommended to prevent distortion and wind-related background noise.
3. If you experience audio issues, verify that the cables are correctly connected.
4. If you're not receiving audio, ensure that the devices are properly paired (coded). Refer to the pairing guide above if necessary.
5. It's possible to mute the devices. If you're not getting audio, please check the volume levels on the devices.
6. If you continue to experience interference, try switching to a different channel.
7. If your issue remains unresolved despite the above suggestions, please contact us at www.a-dena.com for further technical support.

